



APPLICATION:

For observation of filling and flow in pipelines. This sight glass allows reliable monitoring of the function and performance of individual equipment as well as entire installations.

Type 550 flow sight glasses are suitable for mounting on flanges according to DIN EN 1092-1. The sight glasses are supplied pre-assembled and ready for installation.

INSTALLATION NOTE:

Gaskets suitable for the sealing surfaces should be used. The screw material should be equivalent to or higher than those of the sight glass body. Always use screws that match the hole pattern. If possible, the screw thread and the screw head should be lubricated.

According to DIN 3237 with flange connections according to DIN 1092-1 ($\Delta P \leq 10 / 16 / 25 / 40$ bar)

Operating conditions:

Temperature: (depending on glass and gasket)	150 °C 280 °C
Pressure:	$\leq 10 / 16 / 25 / 40$ Bar

Materials:

Body:	GG25; GS-C 25; 1.4408
Glass:	Borosilicate glass DIN 7080 Soda lime glass DIN 8902
Gasket:	PTFE; FKM; NBR; C4400; Silicone; EPDM; Graphite
Screws:	A4-70
Special materials on request	

DESIGN:

DN15 - 50 Square flange version
(see illustration)
DN65 - 200 Round flange version

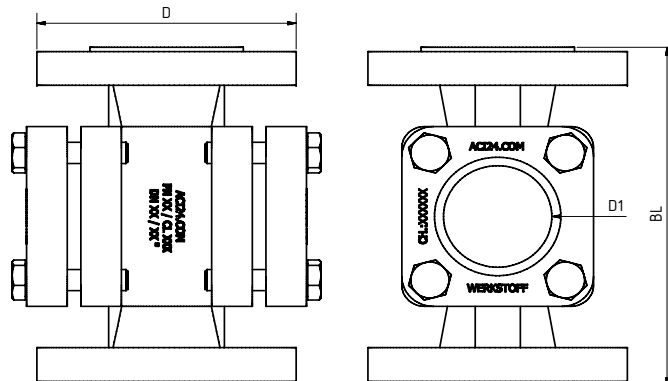

DN	15	20	25	32	40	50	65	80	100	125 ¹	150 ¹	200 ¹
D (PN16)	95	105	115	140	150	165	185	200	220	250	285	340
D (PN25)	similar to PN16								235	270	300	360
D (PN40) ¹	similar to PN25											
BL	130	150	160	180	200	230	290	310	350	400	480	600
D1	32	32	48	48	65	80	80	100	125	150	175	175

¹ similar to DIN 3237

VARIANTS:

ROTOR PLASTIC (120°C) OR PTFE (260°C):

A liquid flow is indicated through rotation of the rotor. As a result, flow control is much easier and quicker to detect.



FLAP MADE OF 1.4571:

A liquid flow is indicated by opening and moving the flap. In this way it is easier and quicker to check the flow rate.



VACUUM VERSION WITH O-RING:

In the case of vacuum, there is a risk whereby the gasket can be pulled inwards and the external medium can enter the valve. For medium vacuum, a PTFE seal should be used, for higher vacuum, an O-ring seal made of Viton is required.



DOUBLE GLAZING:

Double glazing ensures additional safety in the case of damage to the inner glass. The additional glass prevents distribution of medium and possible glass splinters in case of damage or even destruction of the inner glass.

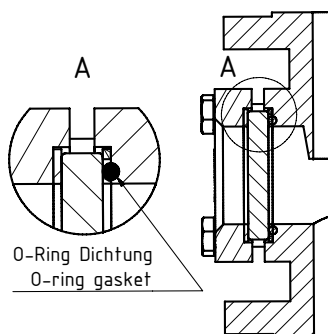

PRODUCTCODE:

Group	TYPE	DN	PN	Body*	Glass	Gasket	Variant
11	550	1: 15 2: 20 3: 25 4: 32 5: 40 6: 50 7: 65 8: 80 9: 100 10: 125 11: 150 12: 200 13: Special	1: 10 2: 16 3: 25 4: 40	1: GG25 2: GS-C25 3: 1.4408 8: Special	1: Borosilicate glass (Boro) DIN 7080 2: Soda lime glass (NKG) DIN 8902 3: Quartz-glas 4: META®-Glas 8: Special	1: PTFE 2: FKM 3: NBR 4: C4400 5: Silicone 6: EPDM 7: Graphite 8: Special	0: Standard variant 1: Rotor PTFE (260°C) 2: Rotor plastic (120°C) 3: Flap 1.4571 4: Vacuum version 5: Double glazing G: Mica Assigned by ACI if required

INFO: Unless otherwise stated, the factory standard highlighted is supplied.

* Cover flanges made of body material or according to quotation / order confirmation

SPECIAL DESIGNS/OPTIONS:

- a) Rotor made of PTFE or plastic
- b) Flap made of 1.4571
- c) Vacuum version with O-ring
- d) double glazing
- e) LED or halogen lights, ATEX-certified, EX certified
- f) Other options on request

EXAMPLE:

11-550-10-1-3-1-7-1 equals the product code:

ACI Type 550
DN 125
PN 10
body 1.4408
borosilicate glass
gasket graphite
with PTFE rotor

ATTENTION!

The pressure-temperature limits according to DIN EN 1092-1 apply!

Our tool of the same name is available on our website for this purpose.
(www.ACI24.com, in the category Service, Tools)



RECOMMENDATION:

For aggressive media or steam, mica discs should be used to protect the glass.